

Operational Amplifiers

Magic Rules

Application Examples

Op-Amp Introduction

- Op-amps (amplifiers/buffers in general) are drawn as a triangle in a circuit schematic
- There are two inputs
 - **inverting** and **non-inverting**
- And one output
- Also power connections (note no explicit ground)

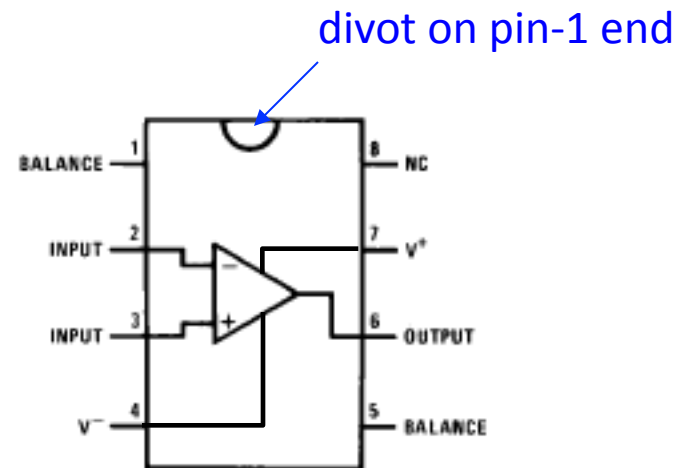
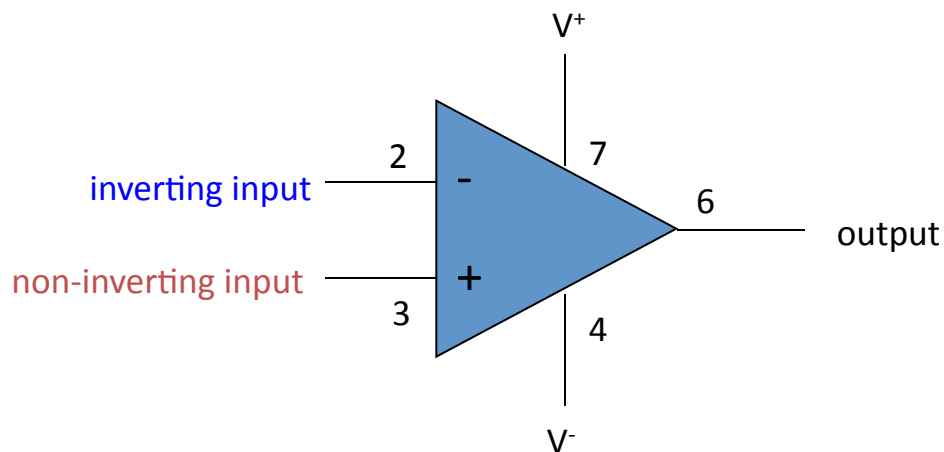

The ideal op-amp

- Infinite voltage gain
 - a voltage difference at the two inputs is magnified infinitely
 - in truth, something like 200,000
 - means difference between + terminal and - terminal is amplified by 200,000!
- Infinite input impedance
 - no current flows into inputs
 - in truth, about $10^{12} \Omega$ for FET input op-amps
- Zero output impedance
 - rock-solid independent of load
 - roughly true up to current maximum (usually 5–25 mA)
- Infinitely fast (infinite bandwidth)
 - in truth, limited to few MHz range
 - slew rate limited to 0.5–20 V/ μ s

Op-amp without feedback

- The internal op-amp formula is:

$$V_{\text{out}} = \text{gain} \times (V_+ - V_-)$$

- So if V_+ is greater than V_- , the output goes positive
- If V_- is greater than V_+ , the output goes negative

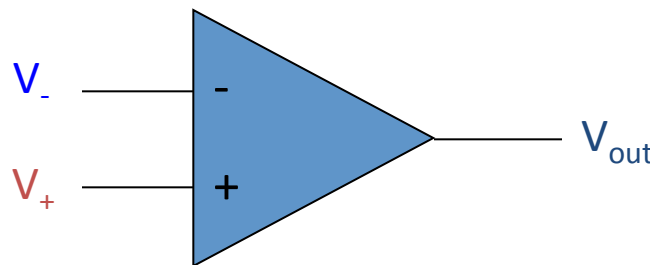

- A **gain** of 200,000 makes this device (as illustrated here) practically useless

Infinite Gain in negative feedback

- Infinite gain would be useless except in the self-regulated negative feedback regime
 - **negative feedback** seems bad, and **positive** good—but in electronics **positive feedback** means runaway or oscillation, and **negative feedback** leads to stability
- Imagine hooking the output to the inverting terminal:
- If the output is less than V_{in} , it shoots positive
- If the output is greater than V_{in} , it shoots negative
 - result is that output quickly forces itself to be exactly V_{in}

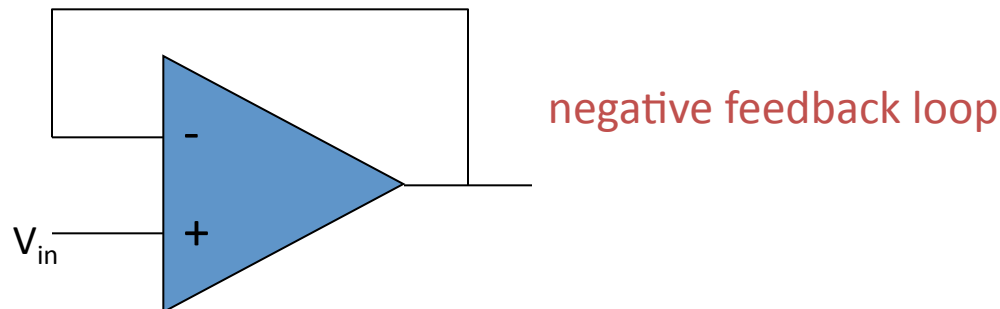

Even under load

- Even if we load the output (which as pictured wants to drag the output to ground)...
 - the op-amp will do **everything it can** within its current limitations to drive the output until the inverting input reaches V_{in}
 - negative feedback makes it **self-correcting**
 - in this case, the op-amp drives (or pulls, if V_{in} is negative) a current through the load until the output equals V_{in}
 - so what we have here is a **buffer**: can apply V_{in} to a load **without burdening** the source of V_{in} with *any* current!

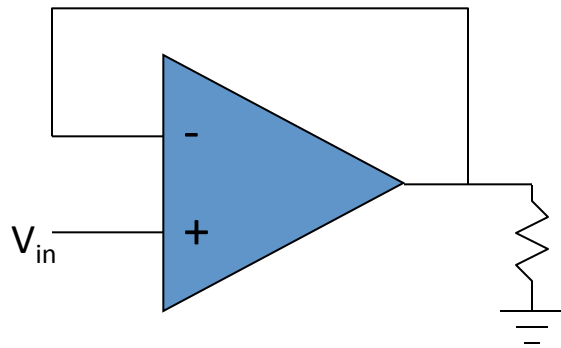

Important note: op-amp output terminal sources/sinks current **at will**: **not like** inputs that have no current flow

Positive feedback pathology

- In the configuration below, if the + input is even a smidge higher than V_{in} , the output goes way positive
- This makes the + terminal even *more* positive than V_{in} , making the situation worse
- This system will immediately “rail” at the supply voltage
 - could rail either direction, depending on initial offset

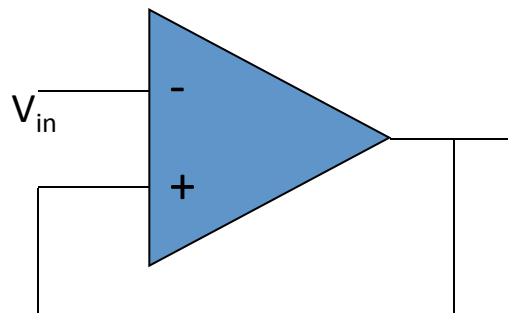

positive feedback: BAD

Op-Amp “Golden Rules”

- When an op-amp is configured in *any* negative-feedback arrangement, it will obey the following two rules:
 - The inputs to the op-amp **draw or source no current** (true whether negative feedback or not)
 - The op-amp output will do **whatever it can** (within its limitations) to make the **voltage difference** between the two inputs **zero**

Inverting amplifier example

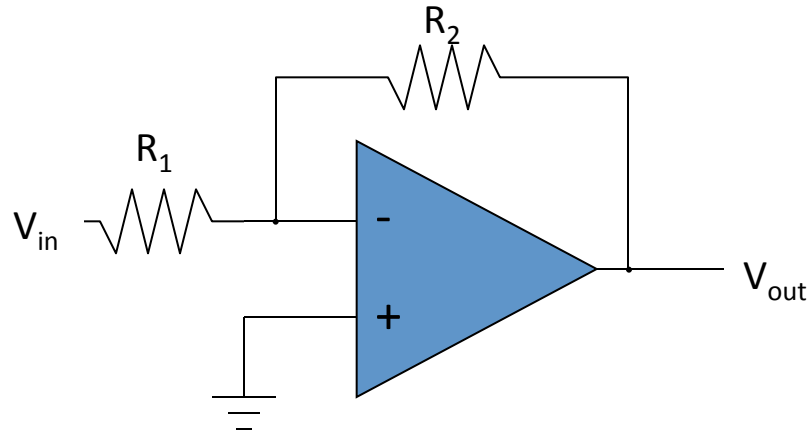

- Applying the rules: - terminal at “**virtual ground**”
 - so current through R_1 is $I_f = V_{in}/R_1$
- Current does not flow into op-amp (one of our rules)
 - so the current through R_1 must go through R_2
 - voltage drop across R_2 is then $I_f R_2 = V_{in} \times (R_2/R_1)$
- So $V_{out} = 0 - V_{in} \times (R_2/R_1) = -V_{in} \times (R_2/R_1)$
- Thus we amplify V_{in} by factor $-R_2/R_1$
 - negative sign earns title “inverting” amplifier
- Current is *drawn into* op-amp output terminal

Non-inverting Amplifier

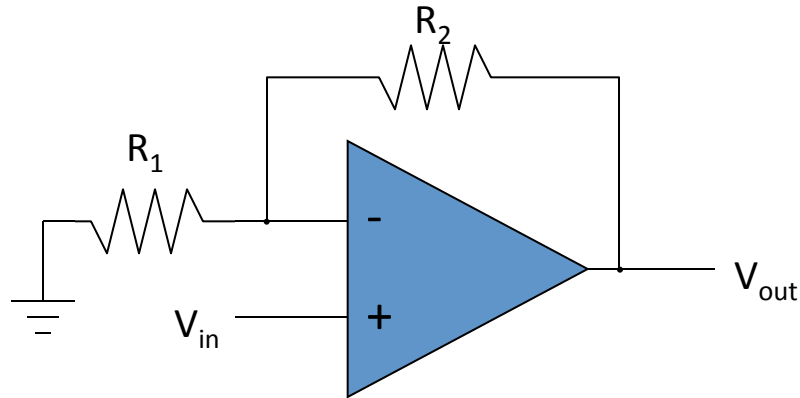

- Now neg. terminal held at V_{in}
 - so current through R_1 is $I_f = V_{in}/R_1$ (to left, into ground)
- This current cannot come from op-amp input
 - so comes through R_2 (delivered from op-amp output)
 - voltage drop across R_2 is $I_f R_2 = V_{in} \times (R_2/R_1)$
 - so that output is higher than neg. input terminal by $V_{in} \times (R_2/R_1)$
 - $V_{out} = V_{in} + V_{in} \times (R_2/R_1) = V_{in} \times (1 + R_2/R_1)$
 - thus gain is $(1 + R_2/R_1)$, and is positive
- Current is **sourced** from op-amp output in this example

Summing Amplifier

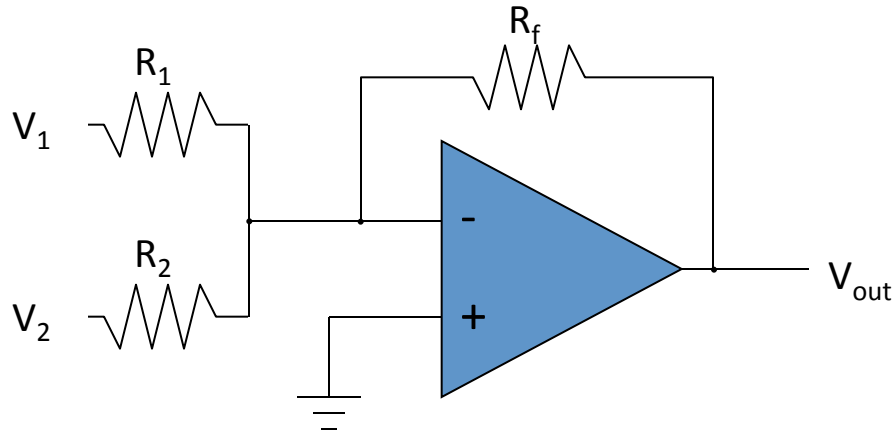

- Much like the inverting amplifier, but with two input voltages
 - inverting input still held at virtual ground
 - I_1 and I_2 are added together to run through R_f
 - so we get the (inverted) sum: $V_{out} = -R_f \times (V_1/R_1 + V_2/R_2)$
 - if $R_2 = R_1$, we get a sum proportional to $(V_1 + V_2)$
- Can have any number of summing inputs
 - we'll make our D/A converter this way

Differencing Amplifier

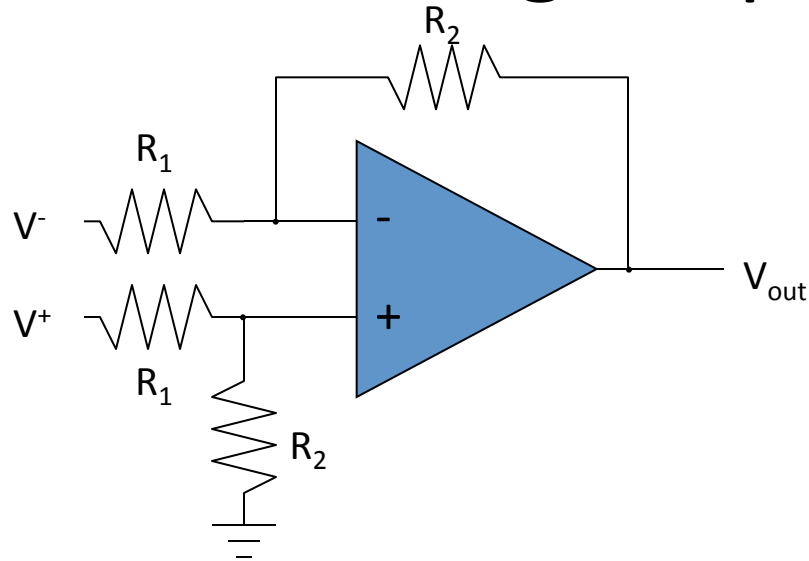

- The non-inverting input is a simple voltage divider:
 - $V_{\text{node}} = V^+ R_2 / (R_1 + R_2)$
- So $I_f = (V^- - V_{\text{node}}) / R_1$
 - $V_{\text{out}} = V_{\text{node}} - I_f R_2 = V^+ (1 + R_2 / R_1) (R_2 / (R_1 + R_2)) - V^- (R_2 / R_1)$
 - so $V_{\text{out}} = (R_2 / R_1) (V^+ - V^-)$
 - therefore we difference V^+ and V^-

Differentiator (high-pass)

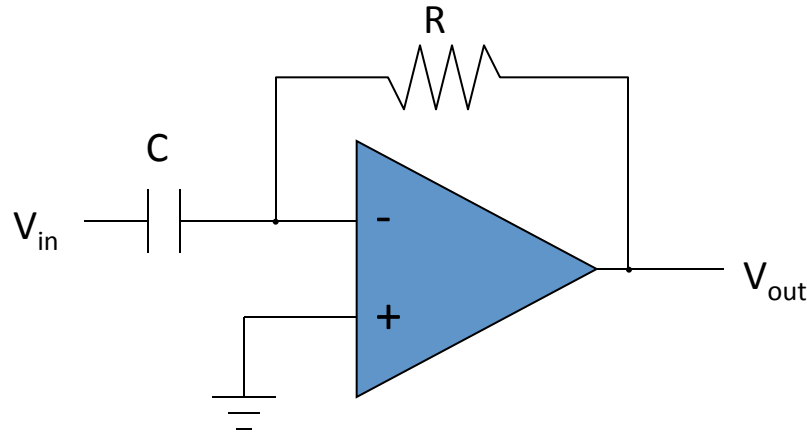

- For a capacitor, $Q = CV$, so $I_{cap} = dQ/dt = C \cdot dV/dt$
 - Thus $V_{out} = -I_{cap}R = -RC \cdot dV/dt$
- So we have a differentiator, or high-pass filter
 - if signal is $V_0 \sin \omega t$, $V_{out} = -V_0 RC \omega \cos \omega t$
 - the ω -dependence means higher frequencies amplified more

Low-pass filter (integrator)

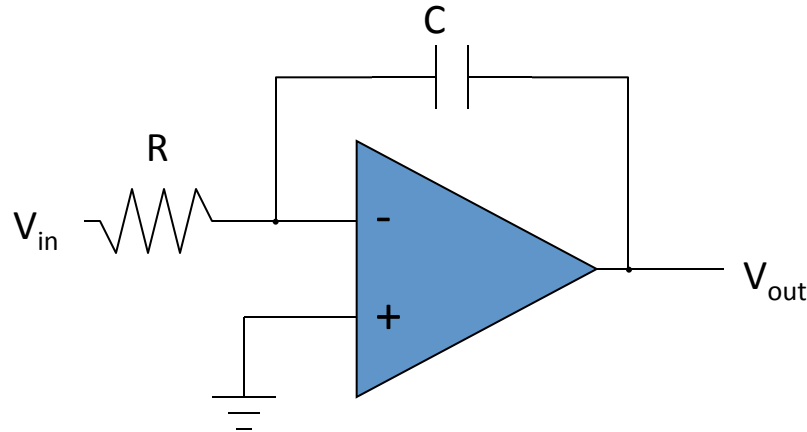

- $I_f = V_{in}/R$, so $C \cdot dV_{cap}/dt = V_{in}/R$
 - and since left side of capacitor is at virtual ground:
 $-dV_{out}/dt = V_{in}/RC$
 - SO $V_{out} = -\frac{1}{RC} \int V_{in} dt$
 - and therefore we have an integrator (low pass)

Notes on RTD readout

- RTD has resistance $R = 1000 + 3.85 \times T(^{\circ}\text{C})$
- Goal: put 1.00 mA across RTD and present output voltage proportional to temperature: $V_{\text{out}} = V_0 + \alpha T$
- First stage:
 - put precision 10.00 V reference across precision 10k Ω resistor to make 1.00 mA, sending across RTD
 - output is -1 V at 0 $^{\circ}\text{C}$; -1.385 V at 100 $^{\circ}\text{C}$
- Second stage:
 - resistor network produces 0.25 mA of source through R9
 - R6 slurps 0.25 mA when stage 1 output is -1 V
 - so no current through feedback \rightarrow output is zero volts
 - At 100 $^{\circ}\text{C}$, R6 slurps 0.346 mA, leaving net 0.096 that must come through feedback
 - If $R7 + R8 = 10389$ ohms, output is 1.0 V at 100 $^{\circ}\text{C}$
- Tuning resistors R11, R7 allows control over offset and gain, respectively: this config set up for $V_{\text{out}} = 0.1T$

Hiding Distortion

- Consider the “push-pull” transistor arrangement to the right
 - an npn transistor (top) and a pnp (bot)
 - wimpy input can drive big load (speaker?)
 - base-emitter voltage differs by 0.6V in each transistor (emitter has arrow)
 - input has to be higher than ~ 0.6 V for the npn to become active
 - input has to be lower than -0.6 V for the pnp to be active
- There is a no-man’s land in between where neither transistor conducts, so one would get “crossover distortion”
 - output is zero while input signal is between -0.6 and 0.6 V

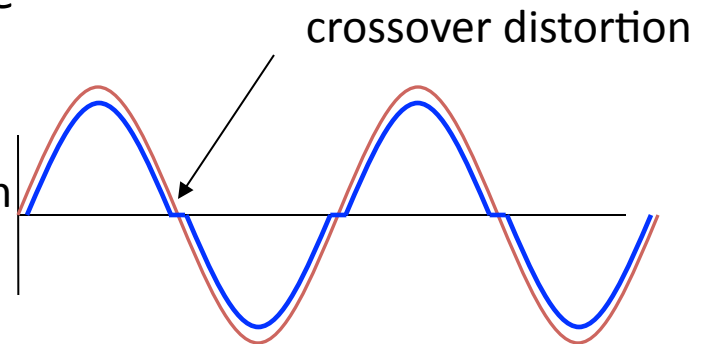
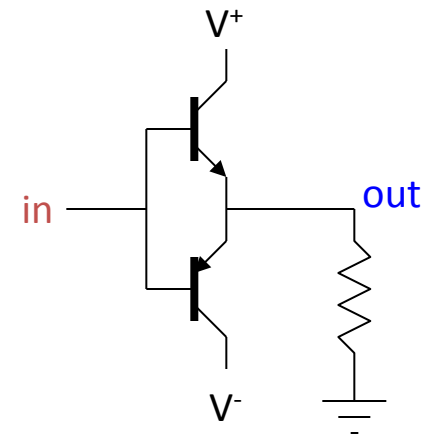

Stick it in the feedback loop!

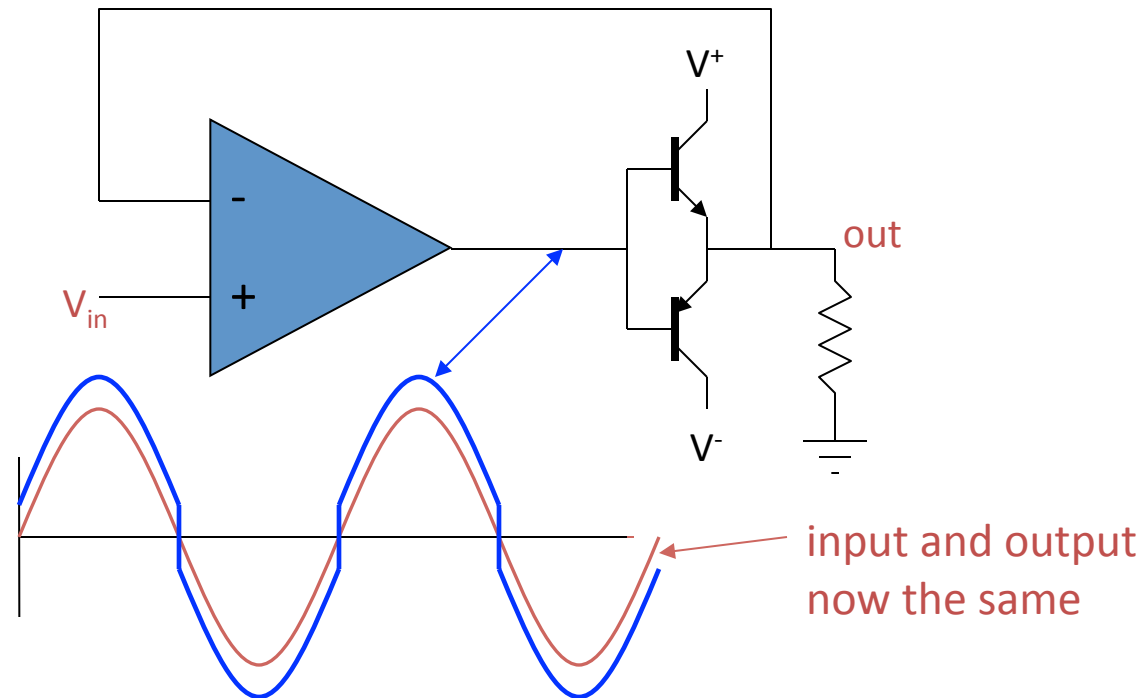

- By sticking the push-pull into an op-amp's feedback loop, we guarantee that the output **faithfully** follows the input!
 - after all, the golden rule demands that **+ input = - input**
- Op-amp jerks up to 0.6 and down to -0.6 at the crossover
 - **it's almost magic**: it figures out the vagaries/nonlinearities of the thing in the loop
- Now get advantages of push-pull drive capability, without the mess

Dogs in the Feedback

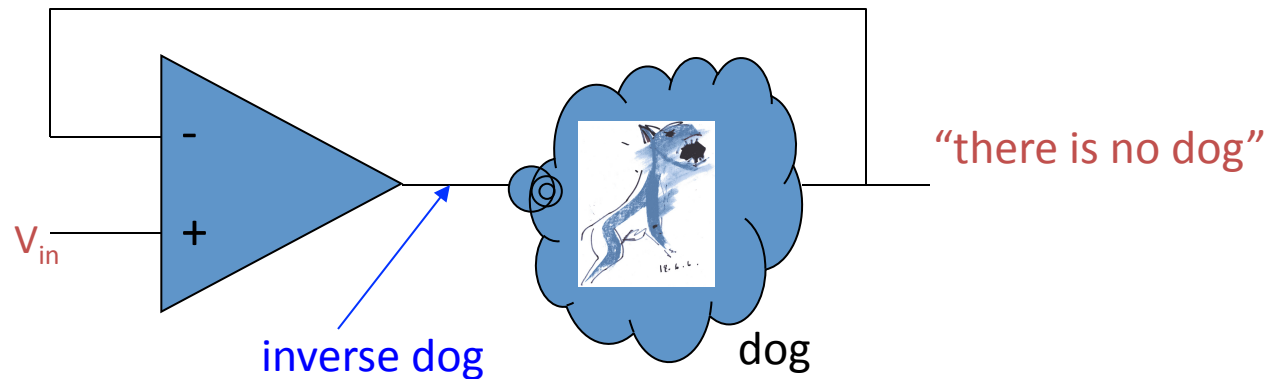

- The op-amp is obligated to contrive the **inverse dog** so that the ultimate output may be as tidy as the input.
- Lesson: you can hide nasty nonlinearities in the feedback loop and the op-amp will “**do the right thing**”

We owe thanks to Hayes & Horowitz, p. 173 of the student manual companion to the *Art of Electronics* for this priceless metaphor.

Reading

- Read 6.4.2, 6.4.3
- Pay special attention to Figure 6.66 (6.59 in 3rd ed.)